



Insights and best practice

AMPLIFIER KNOW-HOW



TECHNICAL NOTE 0111

AMPLIFIER SELECTION WHAT YOU NEED TO KNOW

The challenge

There are many types of RF and Microwave amplifiers available on the market today. They come in many form factors, technology types and bias classes which can make choosing the correct amplifier that meets your application requirements difficult.

A practical guide to eliminate the risk

Manufacturers promote their products in different ways focusing different specifications. The aim of this document is to act as a guide to the important points to consider when selecting an amplifier ensuring the product meets the application requirements for EMC, Communications, Aerospace and Defence.

The document is designed to accompany a video recording of a live webinar "Amplifier selection | What you need to know" presented by Nick Jones. Each page of this Technical Note has a time-stamp that corresponds to the relevant section of the video presentation.



Author:
Nick Jones
Product Manager
AMETEK CTS



You can view the [recording here](#)



GO TO VIDEO 00:38

AMPLIFIER CLASS (BASICS)

- Amplifiers with a 360° conduction angle are called **Class A** amplifiers
- Amplifiers with a 180° conduction angle are called **Class B** amplifiers.
- **Class C** is also available and predominantly used for Pulsed applications



Classes of operation are defined in terms of the amplifier's internal transistor bias mode, or the percentage of the time during which the amplifier is "amplifying" or conducting power. A conduction angle of 360° means that the amplifier conducts over the entire input power cycle, whereas a conduction angle of 180° means that the amplifier only conducts over half of the input cycle. A higher or longer, conduction angle means higher linearity, this translates to a more precise reproduction of the input signal at the output of the amp. However a higher linearity can come at the cost of lower efficiency and higher temperatures.

So an amplifier biased with a 360° conduction angle is known as biased in Class A. If this amplifier had an 180° conduction angle it would be biased in Class B. To conduct for a full cycle class B amp transistors are configured in a push pull configuration. The issue though is cross over distortion at the crossing point between each half of the 360 cycle.

A compromise between the two is the Class AB Amplifier This is a combination of "Class A and B. This allows for both halves to conduct at the same time around the waveforms crossover point eliminating the crossover distortion and associated linearity problems leading to reasonable linear performance at a better efficiency.

Due to the large amount of non-linearity they create, Class B amplifiers are generally unsuitable for RF applications, so most if not all CW RF amplifiers are either biased Class A or Class AB. At first glance, Class AB amplifiers seem to have several advantages, such as lighter weight, increased efficiency, and reasonably linear performance. However they are not suitable for all applications where high linearity is required plus they can be more susceptible to damage resulting from high VSWR levels

Learn more at www.ametek-cts.com or you can [contact us here](#)



GO TO VIDEO 02:32

CLASS A VS CLASS A/B ADVANTAGE AND DISADVANTAGE

Amplifier Class	Advantages	Disadvantages
Class A	Produce the best linearity performance to meet application requirements.	Low efficiency
	Produce the lowest Harmonics	Can have high AC power requirements
	No cross over distortion	Generate more heat
	Strong VSWR capabilities	
Class A/B	Higher efficiency	Can have poor linearity performance
	Lower junction temperatures	In many cases Software controlled VSRW foldback protection required.
	Can be smaller in size	Can suffer from cross over distortion impacting signal integrity

We know a chosen bias can affect the overall performance of the amplifier. With class A offering the most accurate reproduction of the input signal, lower harmonic performance, have no cross over distortion and strong VSWR capabilities. However this does come at a cost of low efficiency requiring a higher AC power requirement and will generate more heat.

Class AB amplifiers are more efficient, can offer lower junction temperatures to the internal transistors and are typically smaller in size.

This comes at the cost of linear performance, so although class AB amplifiers are suitable for many applications such as EMC they are not suitable for all applications. They are more susceptible to VSWR damage requiring protection (or fold back) from the amplifier system and in poorly designed instances can suffer from cross over distortion impacting signal integrity.

Learn more at www.ametek-cts.com or you can [contact us here](#)



GO TO VIDEO 03:29

AMPLIFIER SPECIFICATIONS

Specification	Description	Unit of Measure
Gain	Ratio of output power to input power	dB
Gain Flatness	Variation of gain with frequency	+/-dB
Harmonics	Difference between level of fundamental (wanted) signal and any internally generated harmonics	dBc
Saturated Power	Maximum power that can be output from the amplifier at a given frequency (power level is expressed in dB with reference to 1mW)	dBm
Linear Power (P1dB)	P1dB is described as the output power at which the gain has dropped by 1dB from its small signal level, often referred to a linear power level.	dBm
Load VSWR Performance	VSWR (Voltage Standing Wave Ratio) is officially the ratio of the minimum to the maximum voltage along a transmission line.	VSWR

PULSE SPECIFICATIONS

Specification	Description
RISE/FALL TIME	The Rise or Fall time is the time defined for the leading or trailing edge of a pulse measured between 10% to 90% of the defined edge.
Pulse Width	The maximum defined width of pulse
Pulse Rate	The Pulse Repetition Rate or PRF is typically 100 kHz maximum for EMC applications. Some other applications require higher PRF rates as dictated by the requirement.
RF Delay	Difference in time from when a TTL Pulse trigger is applied to when the RF pulse is present.
Pulse On/Off Ratio	The RF Pulse On/Off ratio, or signal to noise ratio for a TWT solution can be as high 80dB. This is achieved by switching off the beam current for each pulse, so the noise floor is reduced with the beam being biased off.
Pulse to Pulse Jitter	Can be defined as the deviation/variation from the leading edge of each repeating pulse.
Pulse Width Jitter	Can be defined as the deviation/variation in the Pulse Width for each repeating Pulse.
Duty Cycle	The time it takes for a given signal to complete an on off cycle and is defined as a percentage or in simpler terms the percentage of on time

Learn more at www.ametek-cts.com or you can [contact us here](#)



GO TO VIDEO 06:13

SATURATED AND P1DB POWER PERFORMANCE

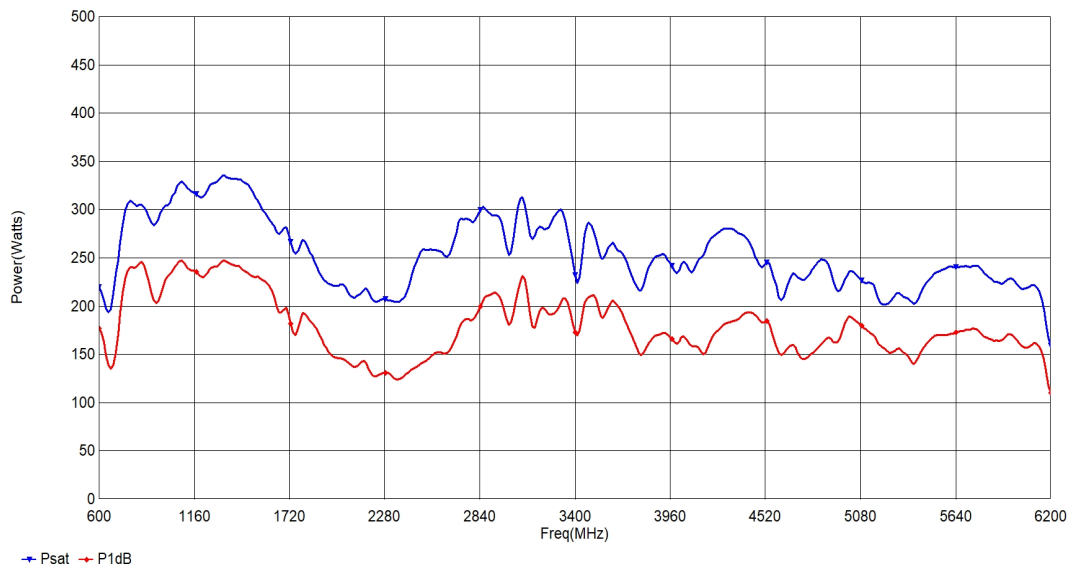

As mentioned earlier most solid-state amplifier datasheet list two types of output power. Saturated power and P1dB power. It's very important to pay attention to these specifications in relation to your application.

For instance, where linear performance is required only the P1dB power, or in this example the red curve should be considered.

If a datasheet does not list the P1dB performance, then this should be considered as it may not meet your application requirements

Learn more at www.ametek-cts.com or you can [contact us here](#)



GO TO VIDEO 06:53

LINEARITY EXPRESSED AS GAIN ERROR

The two charts show different amplifier performance expressed as gain error and is a good example of good and poor linear performance.

The first is typical of a class A amplifier –The perfect state does not exist so there will always be either some slight gain expansion or compression from the zero-point.

To maintain signal integrity the gain error of the amplifier should never exceed +/-1dB before it's specified point. In the case of the chart on the right this is 200W or 53dBm.

So as you can see there is some slight gain expansion up to the point where the specified 200 watts output is achieved. After which the amplifier compresses to it's 1dB point at around 300 watts.

1GHz Gain Error Curve, passes +/-1dB

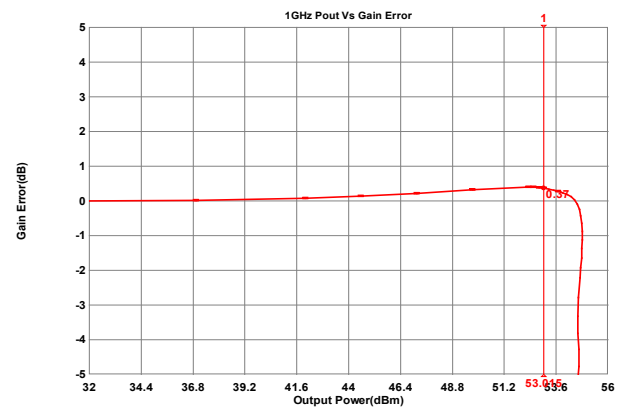

1GHz Gain Error Curve, fails +/-1dB

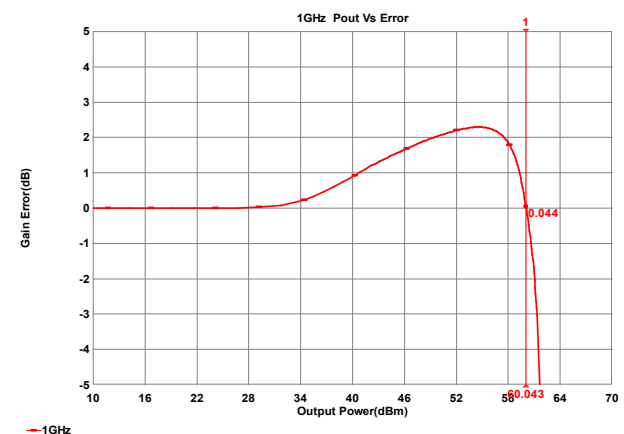

The second graph can be typical of a class A/B amp where the linear performance is not considered as good as the gain error, in this case expansion exceeds +/-1dB before the specified output of 1000W (60dBm) is achieved.

This type of performance can effect the signal integrity of the amplifier, however this performance could be considered usable but for a limited amount of applications where the performance of the amplifier on the right would be considered usable for all applications.

Learn more at www.ametek-cts.com or you can [contact us here](#)



GO TO VIDEO 08:30

VSWR PERFORMANCE PROTECTION, WHAT IS IT

- ▶ Dependent on the match between the amplifier and its load.
- ▶ If the load impedance is not the same as the amplifier impedance some power will be reflected back into the amplifier.
- ▶ This is described as a Voltage Standing Wave Ratio (VSWR)
- ▶ High reflected power conditions can damage the amplifier.

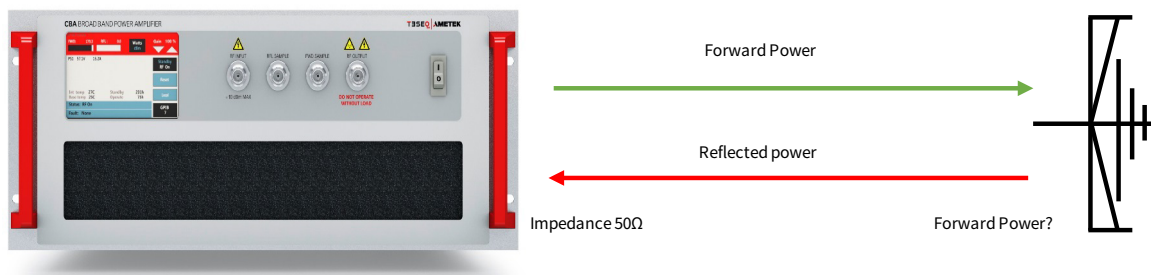

Maximum power transfer of RF energy from an amplifier to a load occurs when the impedance of the load is the same as the impedance of the amplifier. In this case, these two impedances are said to be “matched”, and if you had a lossless transmission line, all of the output power generated by the amplifier will be absorbed by the load. This represents the ideal 1:1 situation and provides maximum power transfer to the load. This is the ideal condition but the reality is, it’s never likely to happen.

So what happens if the load impedance is not the same as the amplifier impedance? In this case, some of the forward RF power transmitted towards the load is returned back to the amplifier.

The relationship between the forward reflected power can be expressed as the ratio of the minimum to maximum voltage or standing waves on the transmission line between amplifier and load and is an effective measure of the match.

This is specified as a Voltage Standing Wave Ratio (VSWR) High reflected power conditions or poor match between amplifier and load can damage certain types of amplifier, so its important amplifier manufactures design their products to be protected. How they do this depends on the class of amplifier design. Some class A amplifiers are 100% hardware protected and do not require additional software to control gain foldback in high VSWR conditions as some class AB amplifiers do.

Note that you can have a high VSWR condition at low output power levels - which most amplifiers can handle. It is only when the amount of reflected power exceeds a certain level that it becomes an issue.

Learn more at www.ametek-cts.com or you can [contact us here](#)



GO TO VIDEO 10:30

■ VSWR PERFORMANCE PROTECTION, WHAT IS IT?

- ▶ Most amplifier manufactures state in their datasheets that their amplifier products have Infinite VSWR performance without damage, all phase angles"
- ▶ Read the VSWR spec small print, how do they achieve this?
- ▶ Is the gain required to be folded back?
- ▶ If so, at what VSWR level?
- ▶ Most amplifiers that require a foldback protection circuit are class AB. Class A can be designed to protect itself using hardware.

So one thing to be mindful of is that all amplifier manufactures state in their datasheets that their amplifier products have Infinite VSWR performance without damage, against all phase angles" It's important to read the VSWR spec and small print;

How do they achieve this?
Is the gain required to folded back?
If so, at what VSWR level?
Does this meet your application requirements?

VSWR	(r)	% Reflected Power
1	0.000	0.00
1.5	0.200	4.0
2	0.333	1.1
2.5	0.429	18.4
3	0.500	25.0
3.5	0.556	30.9
4	0.600	36.0
5	0.677	44.0
6	0.714	51.0
7	0.750	56.3
8	0.778	60.5
9	0.80	64.0
10	0.818	66.9
15	0.875	76.6
20	0.905	81.9
50	0.961	92.3

An example might be, you had a delamination application that requires the amplifier to drive into a poor load providing constant power without suffering any foldback or loss of forward power then a class A product would be required.

Class A can be designed to protect itself using hardware without the requirement to fold back and can be quite happy driving continues power into an open or short circuit condition.

Most amplifier that require some type a foldback protection circuit are class AB though are suitable for many EMC immunity applications though one thing to be mindful off is the growing popularity of reverb chambers. These by there natured generate high VSWR conditions so class A products are a preferred choice. When the gain of the amplifier is required to be folded back to protect the amplifier software is used to control the function.

If the power detector used is not quick enough spikes in power can get through the protection and damage the amplifier so it's important to pay attention when connecting and disconnecting the amp to the load. A misconnection is a common causes for this type of damage where the signal is switched on, the amplifier is presented with what effectively amounts a short or open load condition and doesn't have time to react causing damage.

Learn more at www.ametek-cts.com or you can [contact us here](#)



GO TO VIDEO 12:48

SOLID STATE CW

- ▶ Use transistors rather than tube technology
- ▶ Silicon (LDMOS - Laterally Diffused), Gallium Arsenide (GaAs) Gallium Nitride (GaN)
- ▶ Can handle CW and pulsed signals.
- ▶ As these devices have different properties it can effect the design size and efficiency.
- ▶ It can affect some of the parameters of the amplifier such as linearity, so its important for the user to select an amplifier based on the specification than the internal technology.



There are many types of amplifier available on the market today. From different technology, Solid state to TWT. Different functionality CW to pulsed to different fit and forms.

All of these factors need considering when making an amplifier selection to meet not only your application requirements but also your environment requirements.

Solid state use ever evolving RF transistors rather than tube technology these include Gallium Arsenide (GaAs) and the more commonly used Gallium Nitride (GaN). As these devices have different properties, they can effect the amplifier design, size and efficiency.

So its important for the user to select an amplifier based on the specification than the internal technology. Solid state amplifier can produce the specified rated power either continuously or pulsed and are available in many frequency, power, fit and form combinations.

The relationship between Frequency and power is that there is more power available at the lower end of the spectrum and then gradually declining as the frequency is increased. For pulsed operation CW amplifier can have a duty cycle up to 100%, though it's important to note the output power will diminish at high duties. Higher power can be achieved at a lower duty as the efficiency of the amplifier improves.

Learn more at www.ametek-cts.com or you can [contact us here](#)



GO TO VIDEO 14:18

TWT CW

- ▶ Travelling Wave Tubes use vacuum tube technology.
- ▶ Much higher powers at frequencies can be produced than currently available solid-state amplifiers.
- ▶ Powered from high voltage power supplies.
- ▶ Like Solid State can produce the specified rated power continuously.
- ▶ Produce higher harmonics



At selected powers and frequencies TWT are still have a size, performance and efficiency advantage over developing solid state solutions.

The tubes are powered from high voltage power supplies (typically up to 10kV) and require a start up procedure of a few minutes to warm the cathode emitter before operation. Like the solid-state CW amplifier they can produce the specified rated power continuously. TWTs tend to produce higher harmonics and so harmonic filters are sometimes required and are usually an optional extra.

One point to Note though is that TWT noise figure is typically >25dB higher than for a solid-state solution. This can have significant impact when you multiply it by the bandwidth.

Learn more at www.ametek-cts.com or you can [contact us here](#)



GO TO VIDEO 15:11

PULSED TWT

- ▶ Some applications only require short bursts of very high-power RF.
- ▶ TWT pulsed amplifiers Can modulate a CW signal themselves using grid modulation - they can also accept pulse modulated signals but require synchronization.
- ▶ GT (Gridded TWT) whilst pulsed with a high on/off ratio it cannot produce any higher power during the pulse than it can CW.
- ▶ PT (Pulsed TWT) can produce very much higher power but only at the specified duty cycle (typically 6%).



A pulsed TWT is only capable of producing pulse power. The design is configured to focus the beam current at the specified voltages.

These amplifiers can modulate a CW signal themselves using grid modulation - they can also accept pulse modulated signals but require synchronization. The beam must be limited to a certain duty cycle, typically 6%, so the internal components of the TWT do not exceed the specified ranges. If it's run at higher than specified duty cycles the TWT components will be overloaded and a failure can occur. This is because the closer the TWT is forced into a CW operation state the higher the power dissipation requirement becomes, causing the tube to eventually burn out.

At the specified duty cycles, Pulsed TWT can produce powers in the K watts range and are ideal for EMC immunity and A&D applications.

Learn more at www.ametek-cts.com or you can [contact us here](#)



GO TO VIDEO 20:12

SOLID STATE PULSED

- ▶ In the same way that it is possible to produce pulsed TWT amplifier we can also produce pulsed solid-state amplifiers.
- ▶ The same processes and restrictions apply.
- ▶ The specified power level and duty cycle cannot be exceeded.



In the same way that it is possible to produce pulsed TWT amplifier we can also produce pulsed solid-state amplifiers which are typically biased in Class C.

For class C pulsed amplifiers the same duty cycle restrictions can apply meaning the specified power level and duty cycle cannot be exceeded.

Due to there high efficiency class C pulse amplifiers can achieve much a higher power outputs than there broadband CW solid state counter parts in a smaller physical size.

Learn more at www.ametek-cts.com or you can [contact us here](#)



RADIATED IMMUNITY, 10KHZ TO 40GHZ & BCI SYSTEMS

Testing with 80% AM, the output power from the amplifier shall not exceed the P1dB limit. AM requires approximately 3.3 times the CW power

Peak conservation for Automotive requirements.

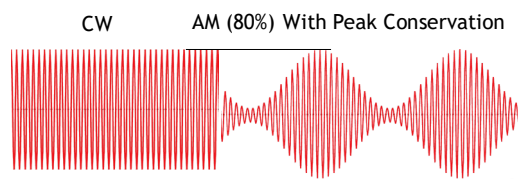
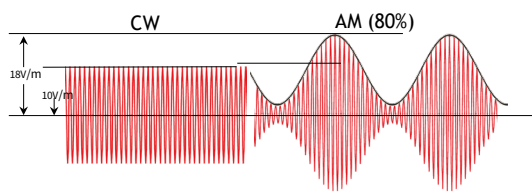

Amplifiers are required to generate the field strengths and currents for radiated immunity testing against the commercial <6GHz, medical, automotive and Military standards.

These standard define the requirements for the measurement and as a result the requirements from the amplifiers such as power output, linearity, CW or pulse operation.

As an example the 80% AM modulation required for the commercial IEC61000-4-3 standard and the Peak Conservation required for Automotive standard ISO11452-2, we would focus on the P1dB output power. If the application requires RF pulses then the saturated power can be considered.

Due to the wide range of requirements from all the different industries a combination of Solid state and TWT often provided the best technical cost-effective solution.

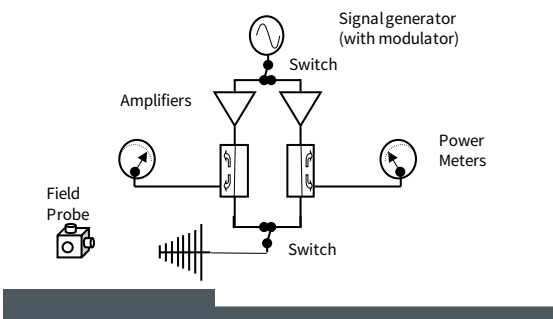

Basic Radiated Immunity System Components

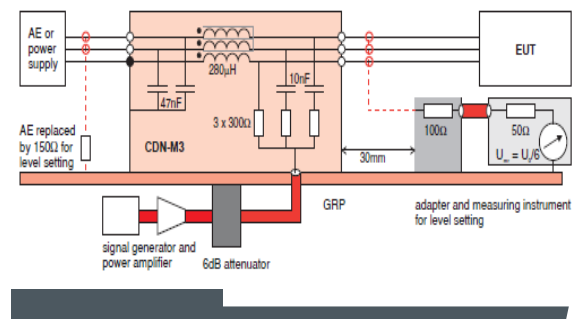

Bulk Current Injection (BCI) EUT Set-up

Learn more at www.ametek-cts.com or you can [contact us here](#)



GO TO VIDEO 17:51

WIDEBAND INTERMODULATION FOR 5G APPLICATIONS

Plotted, in the graph below, are the lower (LSB), upper (USB) and average IM levels as the tone separation is increased from 10kHz to 1GHz. The responses are resonance free.

- ▶ Use wide spacing between the tones.
- ▶ Class A required for accurate signal replication
- ▶ Typically intermodulation properties such as IM3, 5 and 7 as shown in the graph need to be resonance free

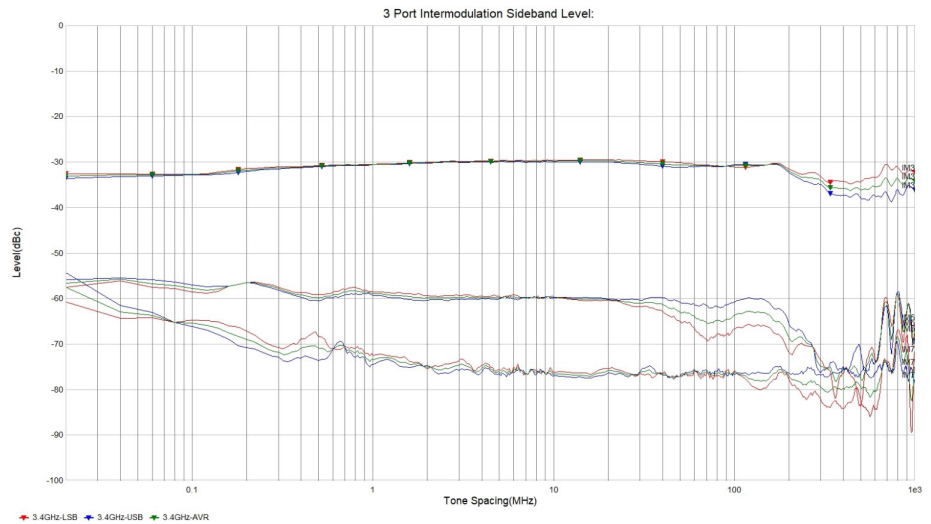

Current 5G infrastructure backhauled below 6GHz uses a modulation scheme based around OFDM, Orthogonal Frequency Division Multiplexing which combines the benefits of Quadrature Amplitude Modulation (QAM) and Frequency Division Multiplexing (FDM) to produce a high-data-rate.

With this high data rate a resonance free wide bandwidth between the tones is required from the amplifier system to achieve promoted 5G performance. In this example, the performance from a 5G system can be analyzed by looking at the signal intermodulation properties, IM3, IM5 and IM7 (shown in graph) that need to be resonance free and without the amplifier collapsing the signal.

The chart shows the average IM levels from a 6GHz amplifier from our Teseq CBA product line set to 3.4GHz with increased tone separation between 10KHz and 1GHz with a resonance free response. A typical OFDM modulated signal actually appears as a noisy band limited response in the frequency domain so IM measurements are a quick way to display the amplifier linearity over a wide bandwidth. As a result this type of application requires Class A for accurate replication of this complex modulation to test infrastructure components.

Learn more at www.ametek-cts.com or you can [contact us here](#)



GO TO VIDEO 19:19

ADDITIONAL TWT APPLICATIONS

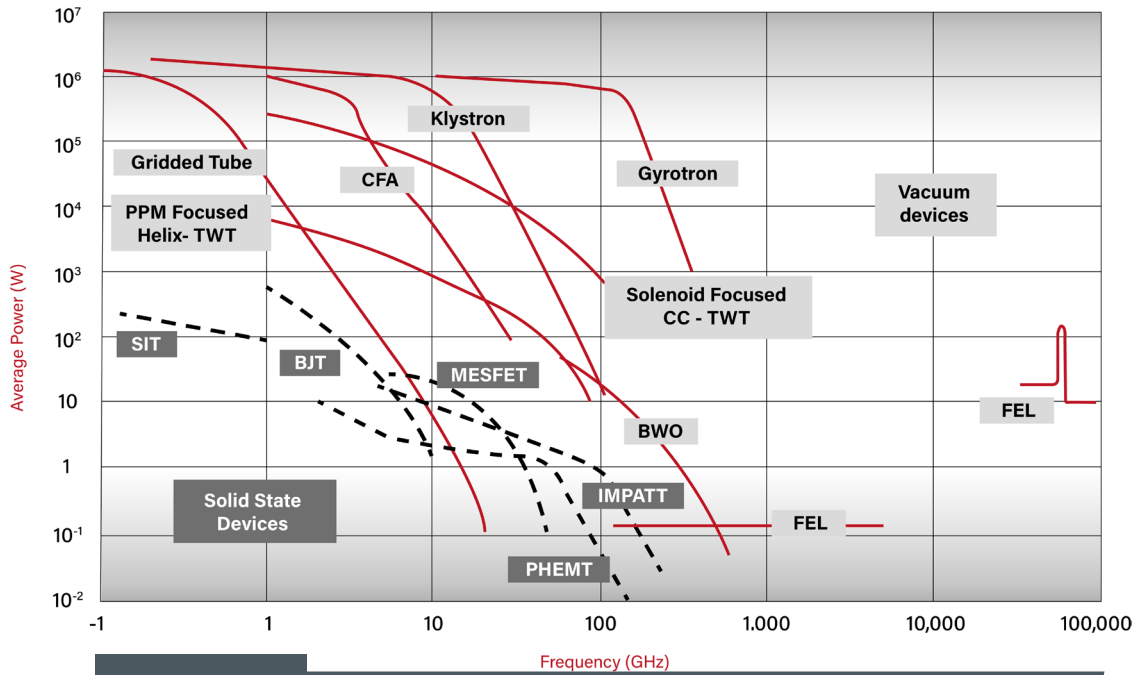

- ▶ Pulsed Radar that require KW peak power.
- ▶ EW applications including, radar jamming and short-range search and rescue.
- ▶ Threat simulators, radar cross section.
- ▶ Sat Comm covering C to KU bands
- ▶ High power component testing
- ▶ High energy physics

Aerospace and defense applications such as Communications, EW and Radar is where TWT are still unparalleled in performance

CW TWT covering the L to Ku bands and Pulsed TWT covering the S to Ka bands are used for surveillance, radar jamming, Targeting systems and short-range search and rescue applications. Threat simulators and Sat comms frequencies also fall into this domain along with high power component testing and high energy physics.

The chart in this slide give a good visual example for the power and frequency offering for the different type's amplifier technology.

It's also important to remember in many of these applications fit and form are just as important as the frequency and power requirements as not all amplifier built form the same technology coving the same frequency and power are designed and built the same.

Learn more at www.ametek-cts.com or you can [contact us here](#)



GO TO VIDEO 20:29

SUMMARY

- ▶ Amplifier Class is important dependent on application
- ▶ Frequency and Power requirement (technology)
- ▶ CW or Pulsed
- ▶ VSWR considerations
- ▶ Fit and form

Always read the specification as RF power cost money. If there is any doubt, then consult our experts. We're here to help engineers with amplifier selection, and to ensure you find the right cost-effective solution to meet your application needs.

If you have a question or need some help [contact us here](#)

About Nick Jones

Nick is the Amplifier Product Manager for AMETEK CTS. With 20 years of experience in the RF & Microwave amplifier industry, Nick has a comprehensive understanding, from tuning and aligning amplifiers through to application expertise.

Nick has a HND in electronic engineering and has held many positions including product testing and production engineering before finally landing in product management.



About AMETEK CTS

AMETEK CTS is a global leader in EMC compliance testing and RF power amplifiers. AMETEK has been designing and manufacturing precision instruments for more than 30 years. Under the brand names of EM Test, Teseq, IFI and Milmega the company produce a wide range of specialist solutions aligned to the individual needs of equipment manufacturers across a variety of industries. These include:

Automotive | Aerospace and Defense | Consumer electronics
Household appliances | Medical devices | Renewable energy

From its design and manufacturing facilities in Switzerland, Germany, the United States and the UK, AMETEK CTS provides customers with innovative solutions to the complex requirements of EMC compliance standards.

Learn more at www.ametek-cts.com or you can [contact us here](#)